



MH series monitor system

MH5A / MH6A / MH8A operating manual

System

The MH series of professional active monitors are designed to produce high SPL output, low distortion, broad bandwidth and low coloration in a shielded design enclosure. They are suitable for a wide variety of applications, such as near field monitoring, mobile vans, broadcast and TV control room, recording studios, MIDI music, and surround sound systems and home studios.

Drivers

Woofers :

- PP woven cone
- heat resistant voice coil
- die-cast aluminum basket
- magnetic shielding
- excellent internal damping
- high power handling
- consistent performance over a wide range of temperature and humidity

Tweeter:

- Air Motor Tweeter (AMT) type
- Magnetically shielded
- Thin film folded diaphragm with etched aluminum voice coil.(Radiating area is 6~10 times larger than a normal 25mm dome tweeter).
- The AMT tweeter has a wide dynamic range, low high frequency distortion and extended frequency response to beyond 28kHz

Tone control

The electronic crossover consists of two band-pass filters in parallel. The slope is 18dB/Oct and crossover frequency is 2.7 kHz/ 2.3 kHz. The active crossover controls (“treble tilt”, “bass tilt” “bass roll-off”) allow precise matching of the loudspeaker to any room environment.

Amplifier

- Variable input sensitivity allows for accurate level matching to your console output
- Protection circuitry for short circuit, over temperature and over voltage.
- The tweeter amplifier features our dynamic over drive protection to prevent hard clipping

Mounting consideration

Please read the manual carefully before mounting.

- Console top mounting :

If the loudspeaker is used for near field monitoring, avoid mounting the speakers on the meter bridge of the console. Instead position them slightly behind the console by using floor stand or wall mounts, this prevents the first reflections from the console surface from

the coloring the direct sound.

- Place the speaker so that its acoustical axis (see figure 1) is aimed towards the listening position. Avoid placing the speaker in a horizontal position as this may cause acoustical cancellation problems around the crossover frequency. If the speaker must be used in horizontal position, please make the tweeter towards to outside. See Figure 1a.
- Place the speaker at ear level for optimum performance.
- If the speaker is installed in a restricted space, sufficient cooling for the amplifier must be ensured. The minimum clearance for the amplifier is 10 centimeters (4inch) to any object. The space adjacent to the amplifier must either be ventilated or sufficiently large to dissipate heat so that the ambient temperature does not rise above 35 degrees Celsius (98F).
- Before connecting, please ensure the mains switch is OFF(see figure 3), and check the mains voltage selector is correctly set (the factory default setting is 230V).
- Before connecting the mains, ensure the volume of the source is adjusted to the lowest level.
- Audio input is via a 10K Ohm balanced XLR connector, but unbalanced leads may be used as long as pin3 is grounded to pin1 of the XLR (see figure 2). Once the connection has been made, the speakers are read to be powered on. Refer to figure 3 for adjustment controls.

Setting the input sensitivity:

Each speaker can be adjusted to match the mixing console output level or other source by using the input sensitivity control on the rear panel. The factory default setting is -6dBu (fully clockwise), which gives full output power at 0.775V input power.

Setting the tone controls:

- The response of the system may have to be adjusted to match the acoustic environment. The adjustment is done by setting the three tone control switch groups ‘treble tilt’, ‘bass tilt’ and ‘bass roll-off’ on the rear panel. The factory setting for these controls are ‘all off’ to give a flat anechoic response.
- See table 1 for suggested tone control settings. Always start adjustment by setting all switches to the ‘OFF’ position. Then set only one switch to the ‘ON’ position to select the response curve needed.
- If more than one switch is set to ‘ON’ (with one switch group) the attenuation value is not accurate.
- TREBLE TILT (4KHz~20KHz): 0 , +2 , -2 , -4dB&MUTE (figure 4)
- BASS TILT (20Hz~600Hz): 0 , -2 , -4 , -6dB&MUTE (figure 5)
- BASS ROLL-OFF (20Hz~100Hz): 0 , -2 , -4 , -8dB (figure 4)

Maintenance

No user serviceable parts are within the amplifier unit. Any maintenance or repair to the MH series units should only be undertaken by qualified service personnel.

Safety considerations

Although the loudspeaker has been designed in accordance with international safety standards, the following warnings and cautions must be observed:

- Servicing must only be performed by qualified service personnel. The amplifier's rear panel must not be opened.
- Do not use this product with an unearthed mains cable as this may lead to personal injury.
- To prevent fire or electric shock, do not expose the unit to water or moisture. Do not place any objects filled with liquid, such as vases on the speaker or near it.
- Note that the amplifier is not completely disconnected from the AC mains service unless the mains power cord is removed from the amplifier or the mains outlet.
- If the fuse needs to be replaced, use the same value AND type.

Warranty

This product has a one year manufacturer's warranty against manufacturing defects that affect the performance of the unit. Refer to the dealer for full warranty terms.

environment	Treble tilt	Bass tilt	Bass roll-off
Free space	None	None	None
Sealed and damped room	None	-2 dB	None
Live room	None	-4 dB	None
Near to reflective surfaces	None	-2 dB	None
corner	None	-4 dB	-4dB

Suggested tone control setting in different environments

Table 1

Figure 2

Need two diagrams, one for vertical and one for horizontal
For horizontal

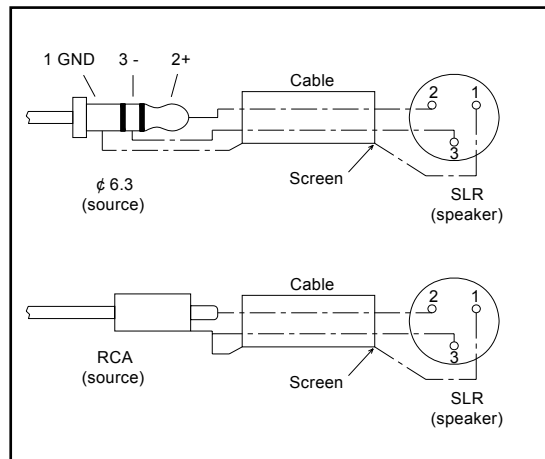

MH5A

Figure 3

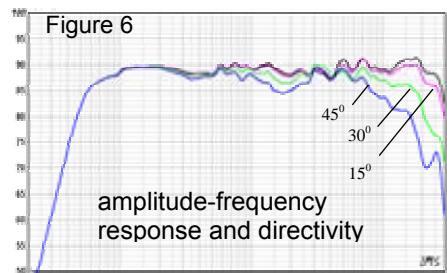
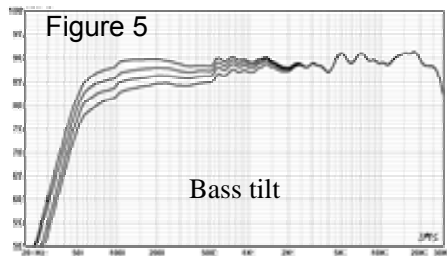
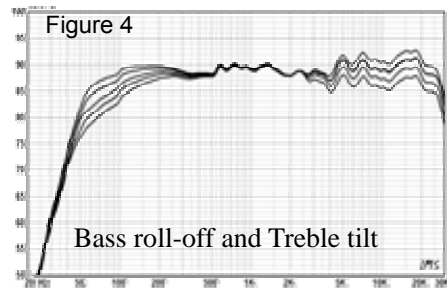
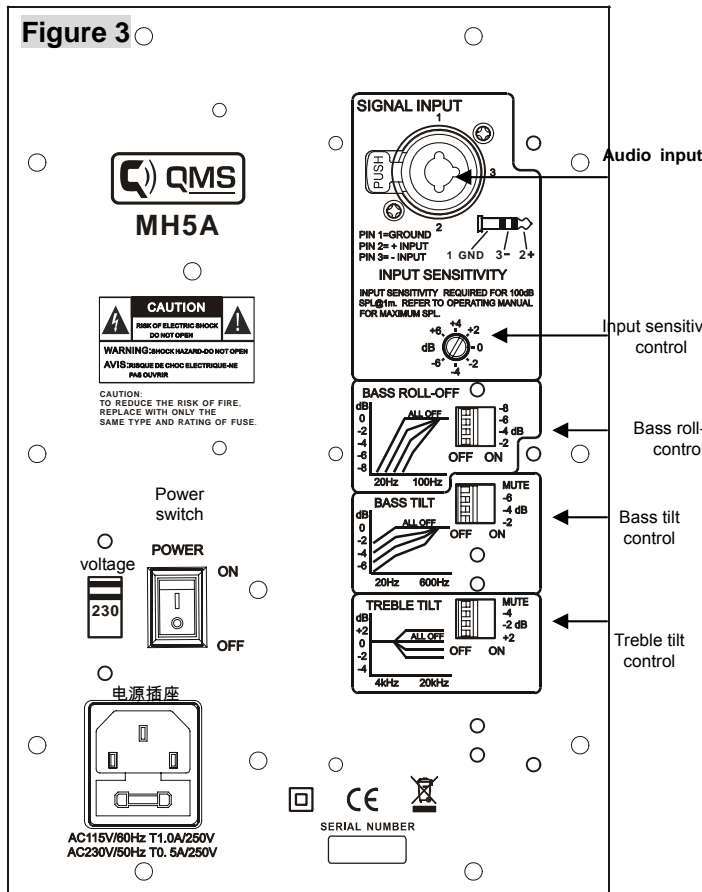

Figure 3

Labels on the right side of Figure 3:
 Audio input
 Input sensitivity control
 Bass roll-off control
 Bass tilt control
 Treble tilt control
 switch
 Mains socket

Figure 4

Figure 5

Figure 6

↑ MH6A

↓ MH8A

Figure 3

Labels on the right side of Figure 3:
 Audio input
 Input sensitivity control
 Bass roll-off control
 Bass tilt control
 Treble tilt control
 switch
 Mains socket

Figure 4

Figure 5

Figure 6

◆ **specification**

specification	MH5A	MH6A	MH8A
Free field frequency response of system (±3dB)	58Hz-28KHz	50Hz-26KHz	50Hz-26KHz
Maximum short term sine wave acoustic output on axis in half space, averaged from 100Hz to 3k Hz (1 pair)	@1m ≥ 108dB SPL @0.5m ≥ 114dB SPL	@1m ≥ 113dB SPL @0.5m ≥ 119dB SPL	@1m ≥ 115dB SPL @0.5m ≥ 121dB SPL
Bass driver	5 inch(135mm) shielding	6.5 inch(165mm) shielding	8 inch(200mm) shielding
Tweeter driver	33*26mm AMT tweeter	60*32mm AMT tweeter	60*32mm AMT tweeter
Weight (KG/PCS)	6.4	12.3	17.8
Size (mm)	H273*W180*D210	H346*W220*D286	H420*W270*D350
XLR input socket	PIN1 grounded、PIN2 +、PIN 3 -		
ϕ 6.3 input socket	PIN1 grounded、PIN2 +、PIN 3 -		
Input impedance	10k Ohm balanced		
Crossover frequency	2.7 KHz	2.3KHz	2.3KHz
Treble tilt	4KHz-20KHz/0、+2、-2、-4dB&MUTE (break)		
Bass tilt	20Hz-600Hz/0、-2、-4、-6dB&MUTE (break)		
Bass roll-off	20Hz-100Hz/0、-2、-4、-6、-8dB		
Input sensitivity control	-6~+6dB The default setting of all tone control is OFF. The input sensitivity control to maximum (fully clockwise)		
Bass amplifier Max short term output power	100 W / 4 ohm	150 W / 4 ohm	200 W / 4 ohm
Treble amplifier Max short term output power	50 W / 4 ohm	100 W / 4 ohm	150 W / 4 ohm
	Long term output power is limited by driver unit protection circuitry.		
Slew rate	80V/μs		
Amplifier system distortion at rated output	THD ≤ 0.05%		
Signal to Noise ratio, referred to full output	Bass > 100 dB Treble > 100 dB		
Mains voltage	User selectable 115V/230V± 10%		



Shenzhen Tekzone Loudspeaker Co., Ltd.

Address: NO. 124, Busha Road, Buji Town, Shenzhen, 518114, P.R. China

Tel: +86-755-2870 3347 2870 0767

Fax: +86-755-2870 1400

E-mail: fox@qmsaudio.com
